

GP Batteries

Data Sheet

Model No.: VCL007

Document Number: SDS0462

Revision: 00

Page 1 of 3

Specifications:

Model No	:	VCL007
For use with	:	Canon Elura 2, Elura 2MC, MV3MC, MV3iMC
Color	:	BLACK (BLK)
Battery Type	:	Lithium Ion
Battery	:	4 x GP1850L130
Nominal Voltage	:	7.4V
Maximum Charge Voltage	:	8.4V
Discharge Cut Off Voltage	:	5.6V
Typical Capacity	:	2600 mAh at 0.2C**
Minimum Capacity	:	2340 mAh at 0.2C**
Temperature Range	:	Charge: 0 ~ 45° C Discharge: -20 ~ 60° C Storage: -20 ~ 45° C
Casing Material	:	ABS+PC
Typical Weight	:	146g
Safety	:	Each battery pack has a protection circuit that would protect against over-voltage, over-discharge and over-current abuses occur. Every Lithium Ion cell is provided with several internal safety features to prevent over-charge, over-current, and to resist physical abuse. Each has a temperature sensitive shut down separator, pressure sensitive tear away tab for current interruption, a safety vent, and the industries only temperature actuated current interrupter.
Warranty	:	Six (6) months limited warranty from date of purchase.

*' Data valid only when the battery pack is on fully charged condition.

***' Battery pack should be firstly charged and discharged for 3 complete cycles as a warm-up.

(Details refer to Lithium-Ion Battery Product Specification.)

Brand names of camcorders are registered trademarks of the respective manufacturers.

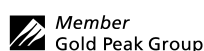

Manufacturer reserves the right to alter or amend the design, model and specification without prior notice.

GP Batteries

Data Sheet

Model No.: VCL007

Document Number: SDS0462

Revision: 00

Page 2 of 3

Mechanical Drawing:

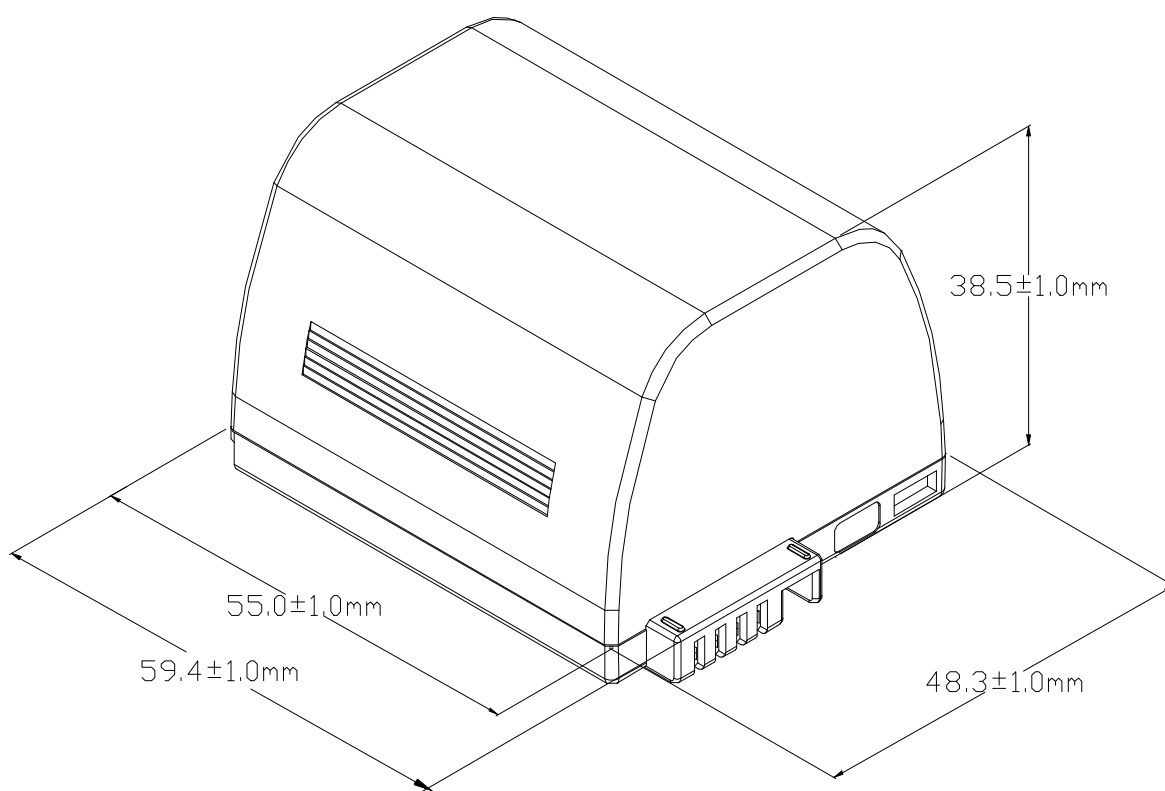

Remark: Dimensions showed are for reference only. For detail, please refer to the engineering drawing.

 Member
Gold Peak Group

Manufacturer reserves the right to alter or amend the design, model and specification without prior notice.

GP Batteries

Data Sheet

Model No.: VCL007

Document Number: SDS0462

Revision: 00

Page 3 of 3

Circuit Diagram:

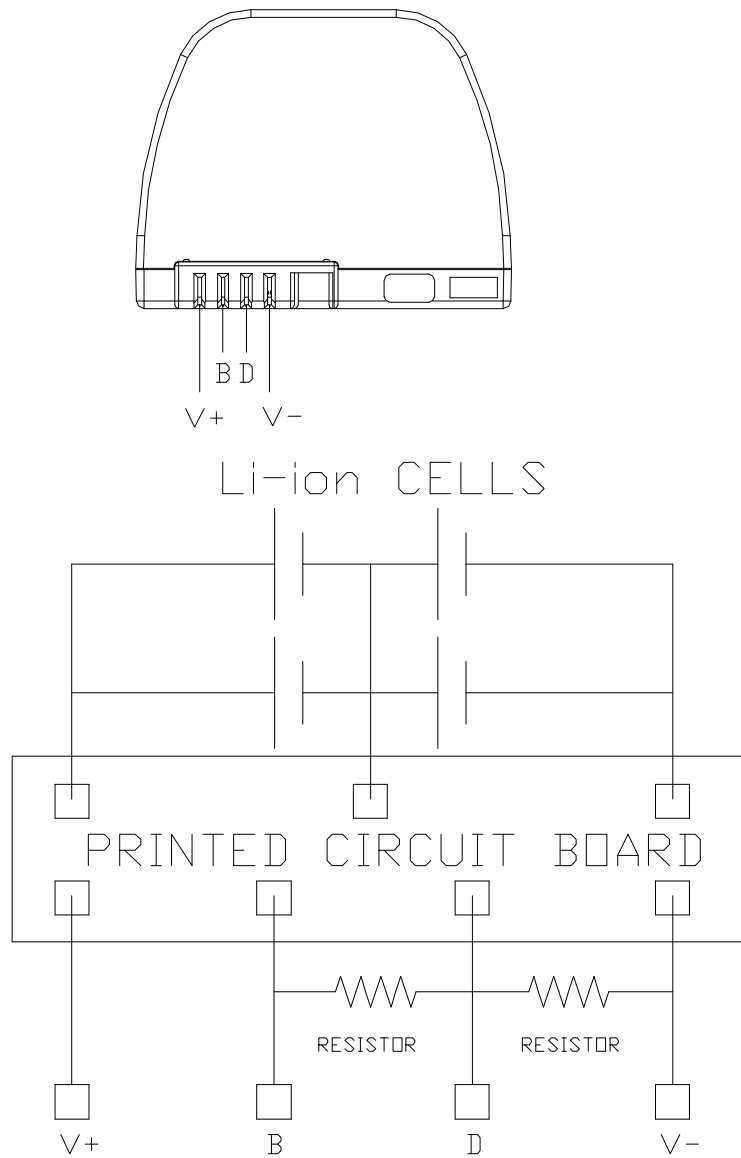

DCV	'V+'-'V-'	7.4V MIN.
RESISTOR	B-V-	99K ohm ±2%
	D-V-	56K ohm ±2%
CHECK POINT	SPECIFICATION	

Distributed by:

MICROBATTERY.COM

7350 NW 35th Terrace, Miami, Florida 33122

Customer Service: 1-866-999-2355 Phone: 1-305-371-9200 Fax: 1-305-371-9400

www.microbattery.com

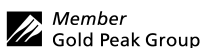

Manufacturer reserves the right to alter or amend the design, model and specification without prior notice.