

GP Batteries

Data Sheet

Model No.: VJL002

Document Number: SDS0506

Revision: 00

Page 1 of 3

Specifications:

Model No	:	VJL002
For use with	:	JVC GR-DV1800, GR-DV2000, GR-DV3000, GR-DVL100, GR-DVL105, GR-DVL107, GR-DVL108, GR-DVL109, GR-DVL120, GR-DVL150/U, GR-DVL157, GR-DVL200, GR-DVL210, GR-DVL257/U, GR-DVL305, GR-DVL307, GR-DVL308, GR-DVL309, GR-DVL310/U, GR-DVL320, GR-DVL355/U, GR-DVL357/U, GR-DVL400, GR-DVL410, GR-DVL450, GR-DVL500, GR-DVL505, GR-DVL507, GR-DVL510/U, GR-DVL515, GR-DVL520, GR-DVL522, GR-DVL555, GR-DVL557/U, GR-DVL600, GR-DVL707, GR-DVL715, GR-DVL720, GR-DVL725, GR-DVL800, GR-DVL805, GR-DVL815, GR-DVL820, GR-DVL910, GR-DVL915, GR-DVL920
Color	:	BLACK (BLK)
Battery Type	:	Lithium Ion
Battery	:	4 x GP1750L100
Nominal Voltage	:	7.4V
Maximum Charge Voltage	:	8.4V
Discharge Cut Off Voltage	:	5.6V
Typical Capacity	:	2000 mAh at 0.2C**
Minimum Capacity	:	1800 mAh at 0.2C**
Temperature Range	:	Charge: 0 ~ 45° C Discharge: -20 ~ 60° C Storage: -20 ~ 45° C
Casing Material	:	ABS+PC
Typical Weight	:	129g
Safety	:	Each battery pack has a protection circuit that would protect against over-voltage, over-discharge and over-current abuses occur. Every Lithium Ion cell is provided with several internal safety features to prevent over-charge, over-current, and to resist physical abuse. Each has a temperature sensitive shut down separator, pressure sensitive tear away tab for current interruption, a safety vent, and the industries only temperature actuated current interrupter.
Warranty	:	Six (6) months limited warranty from date of purchase.

*' Data valid only when the battery pack is on fully charged condition.

***' Battery pack should be firstly charged and discharged for 3 complete cycles as a warm-up.

(Details refer to Lithium-Ion Battery Product Specification.)

Brand names of camcorders are registered trademarks of the respective manufacturers.

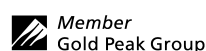

Manufacturer reserves the right to alter or amend the design, model and specification without prior notice.

GP Batteries

Data Sheet

Model No.: VJL002

Document Number: SDS0506

Revision: 00

Page 2 of 3

Mechanical Drawing:

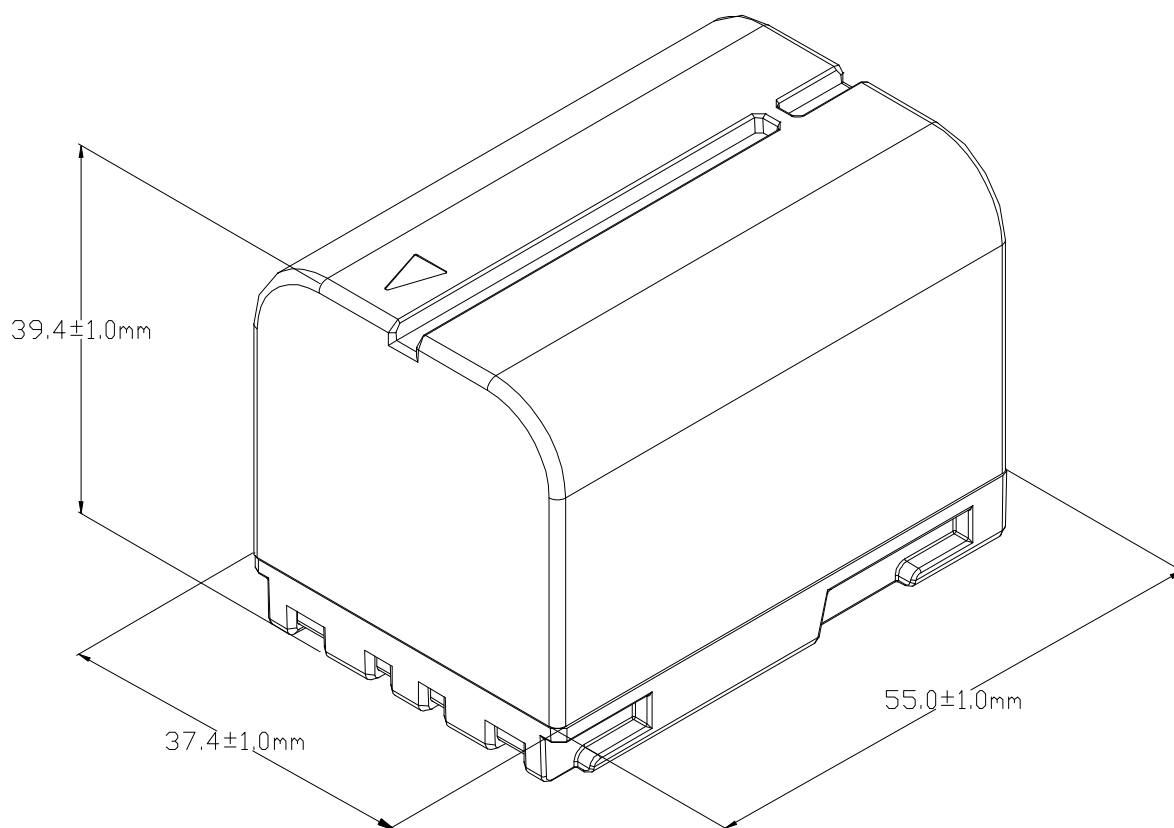

Remark: Dimensions showed are for reference only. For detail, please refer to the engineering drawing.

 Member
Gold Peak Group

Manufacturer reserves the right to alter or amend the design, model and specification without prior notice.

GP Batteries

Data Sheet

Model No.: VJL002

Document Number: SDS0506

Revision: 00

Page 3 of 3

Circuit Diagram:

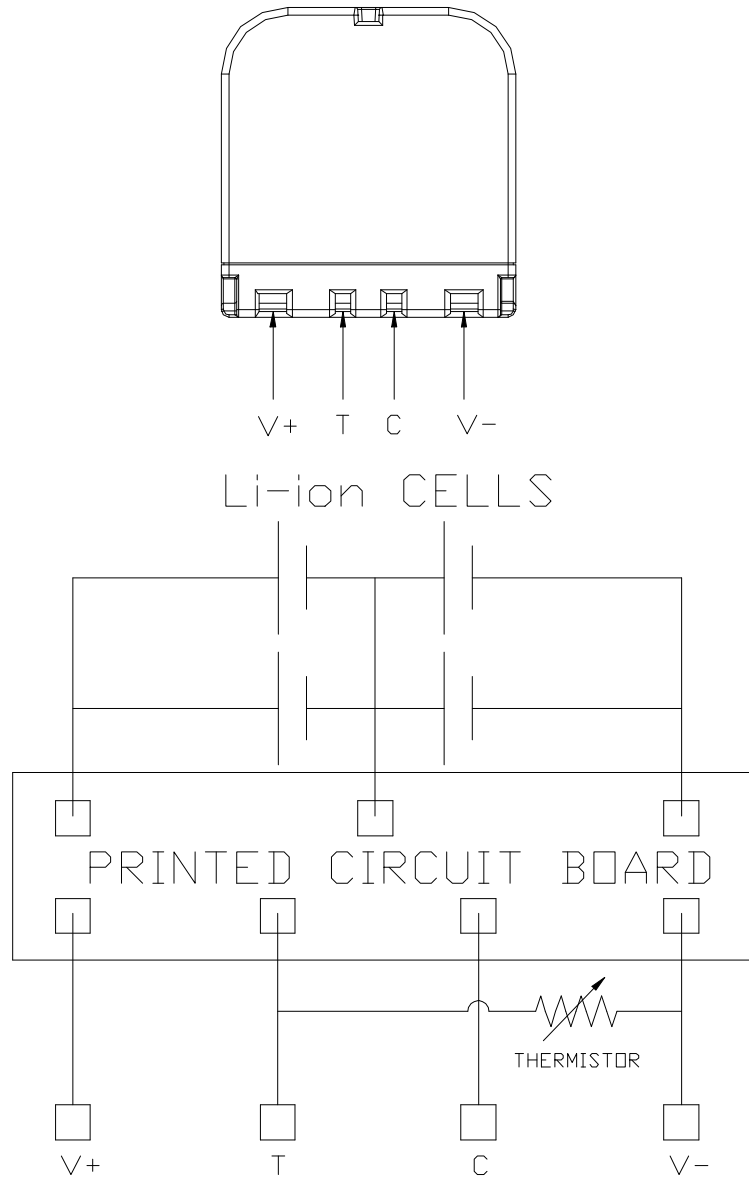

DCV	'V+'-'V-'	7.4V MIN.
THERMISTOR	T-V-	8.8 - 12.7k Ω m (20-27°C)
CHECK POINT		SPECIFICATION

Distributed by:

MICROBATTERY.COM

7350 NW 35th Terrace, Miami, Florida 33122

Customer Service: 1-866-999-2355 Phone: 1-305-371-9200 Fax: 1-305-371-9400

www.microbattery.com

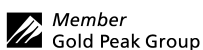

Manufacturer reserves the right to alter or amend the design, model and specification without prior notice.