

GP Batteries

Data Sheet

Model No.: VPL002

Document Number: SDS0340

Revision: 03

Page 1 of 3

Specifications :

Model No	:	VPL002
For use with	:	Panasonic Camcorder
Color	:	Black (BLK)
Battery Type	:	Lithium Ion
Battery	:	2 × GP1750L100
Nominal Voltage	:	7.4V
Maximum Charge Voltage	:	8.4V
Discharge Cut Off Voltage	:	5.6V
Nominal Capacity	:	1000 mAh at 0.2C**
Minimum Capacity	:	930mAh at 0.2C**
Continuous Operating Time*	:	90 mins (LP and LCD on)
Temperature Range	:	Charge : 0 ~ 45°C Discharge : -20 ~ 60°C Storage : -20 ~ 45°C
Casing Material	:	ABS + PC
Typical Weight	:	59.9g
Safety	:	Each battery pack has a protection circuit & thermistor that would protect against over-voltage, over-discharge and over-current abuses occur. Every Lithium Ion cell is provided with several internal safety features to prevent over-charge, over-current, and to resist physical abuse. Each has a temperature sensitive shut down separator, pressure sensitive tear away tab for current interruption, a safety vent, and the industries only temperature actuated current interrupter.
Warranty	:	Six (6) months limited warranty from date of purchase.

*' data valid only when the battery pack is on fully charged condition.

**' Battery pack should be firstly charged and discharged for 3 complete cycles as a warm-up.

(Details refer to Lithium-Ion Battery Product Specification.)

Brand names of camcorders are registered trademarks of the respective manufacturers.

GP Batteries

Data Sheet

Model No.: VPL002

Document Number: SDS0340

Revision: 03

Page 2 of 3

Mechanical Drawing :

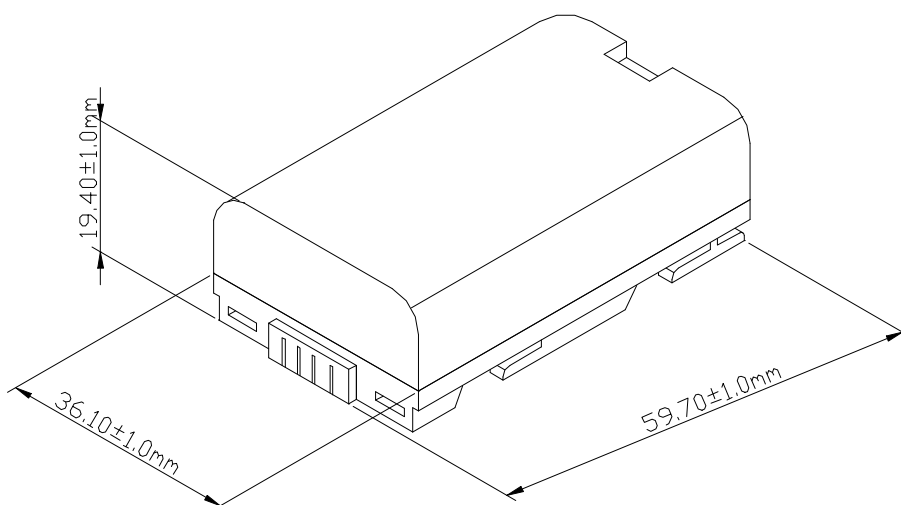

Remark: Dimensions showed are for reference only. For detail, please refer to the engineering drawing.

GP Batteries

Data Sheet

Model No.:VPL002

Document Number: SDS0340

Revision: 03

Page 3 of 3

Circuit Diagram :

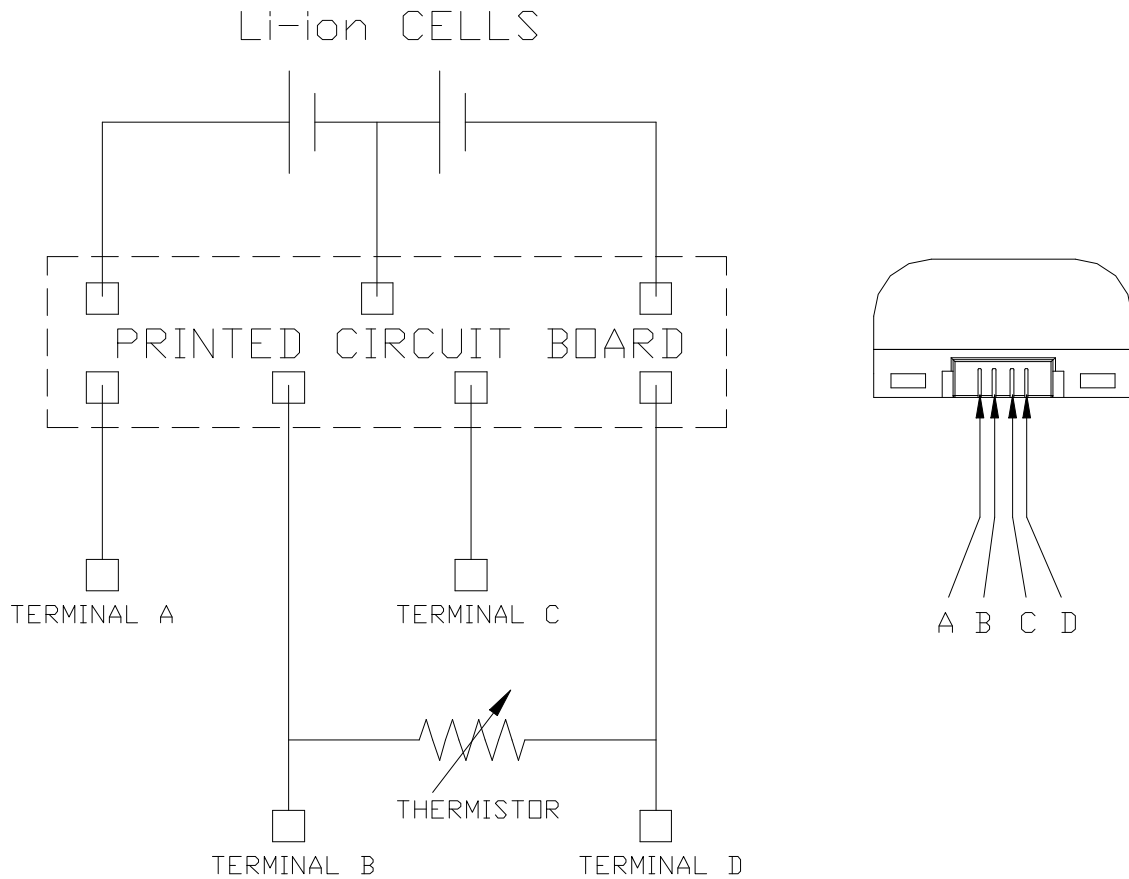

THERMISTOR	B-D	8.3 - 12.1K ohm (20-23°C)
DCV	A-D	7.4V MIN. (A IS +VE TERMINAL)
CHECK POINT		SPECIFICATION

Distributed by:

MICROBATTERY.COM

7350 NW 35th Terrace, Miami, Florida 33122

Customer Service: 1-866-999-2355 Phone: 1-305-371-9200 Fax: 1-305-371-9400

www.microbattery.com